



Bedrijvenweg 4
2351 BC Leiderdorp
the Netherlands

t. +31 (0) 71 58 91 230
f. +31 (0) 71 58 20 658
e. info@sycon.nl

KvK. Leiden 30176290
ABN-AMRO bank 511 661 231
IBAN 47ABNA 0511 661 231
VAT. NL8103.45.018.B.01

www.sycon.nl

finishing

PRIMO PX flooring system

visual documentation

english

print quality A4 RGB



Finishing Primo **PX** flooring system

Covering the surface + edging

For example:

- Wooden flooring

- Carpet

- Laminated flooring

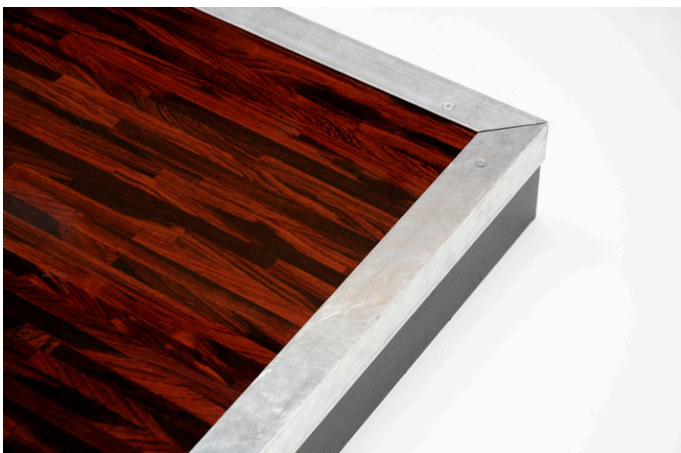

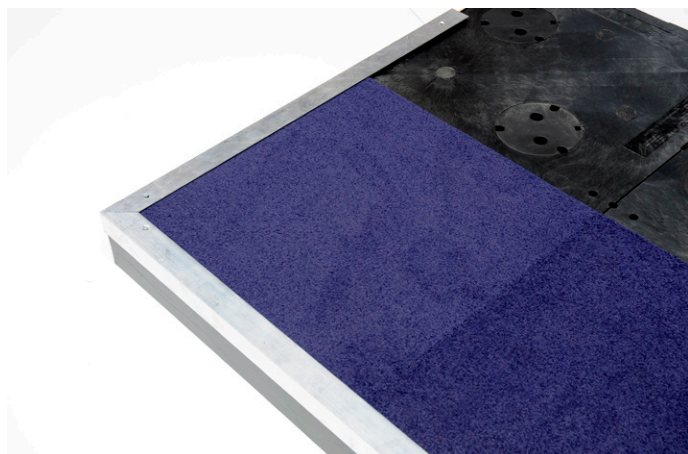
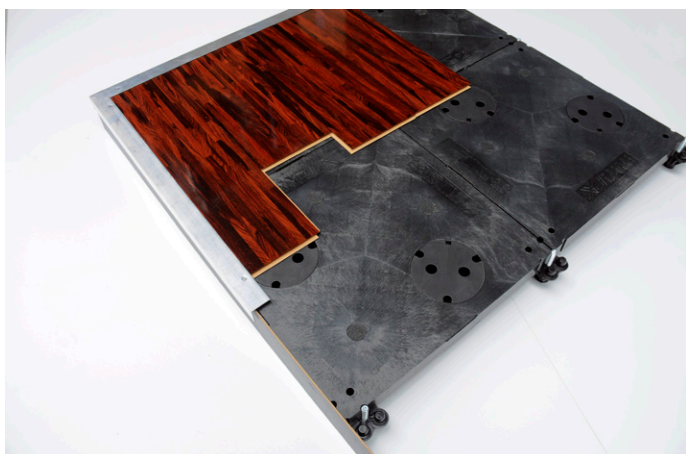
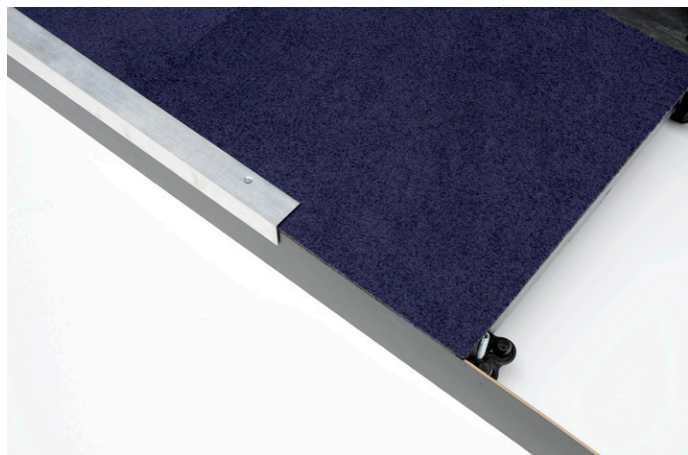
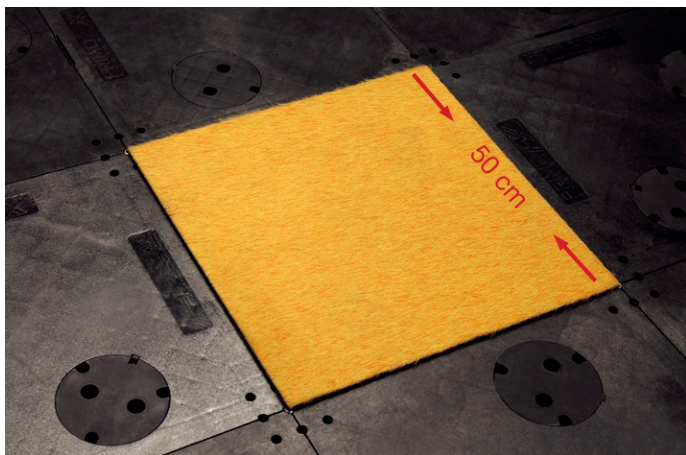

Wheelchair ramp

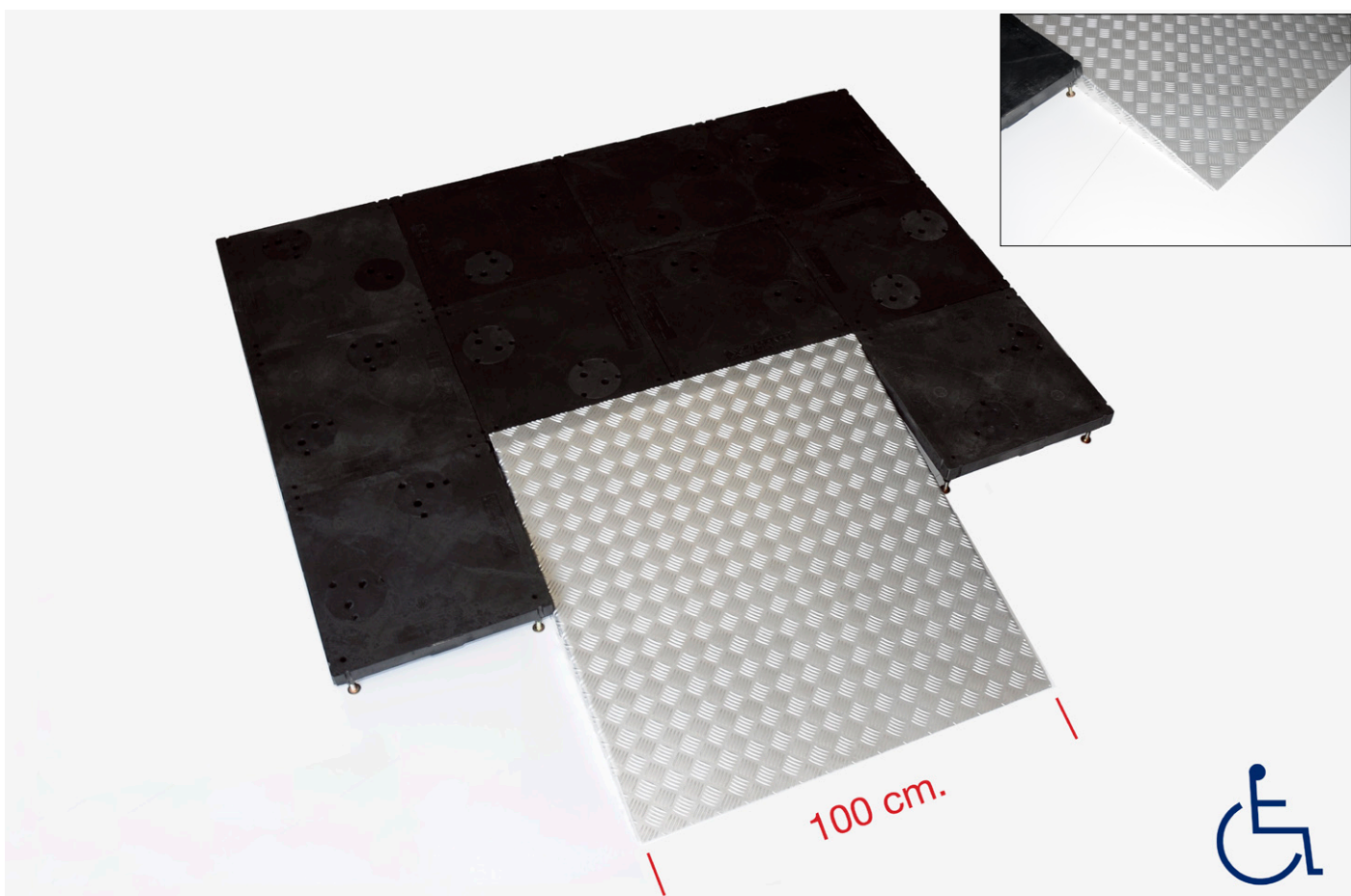

Finishing around pillars

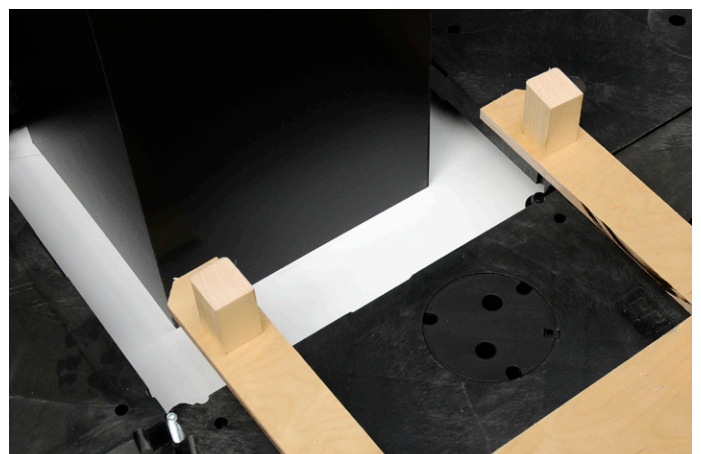
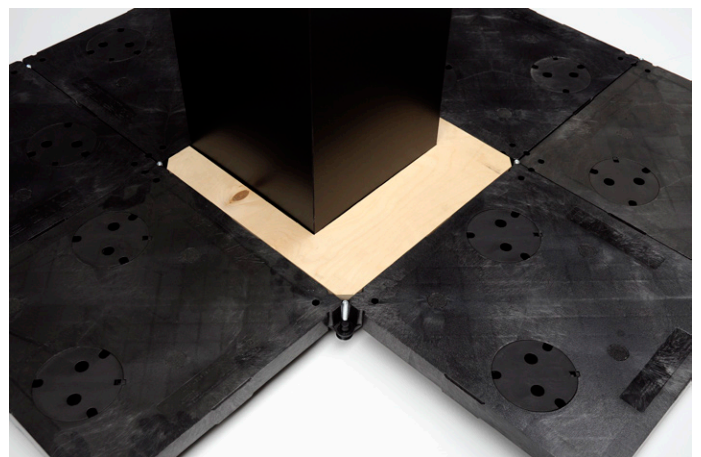
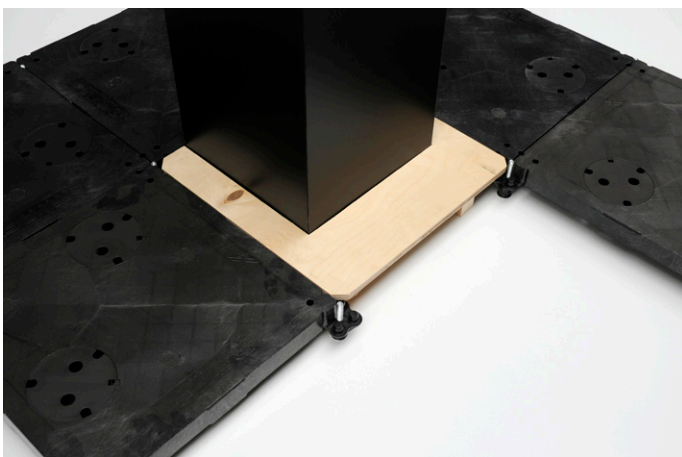
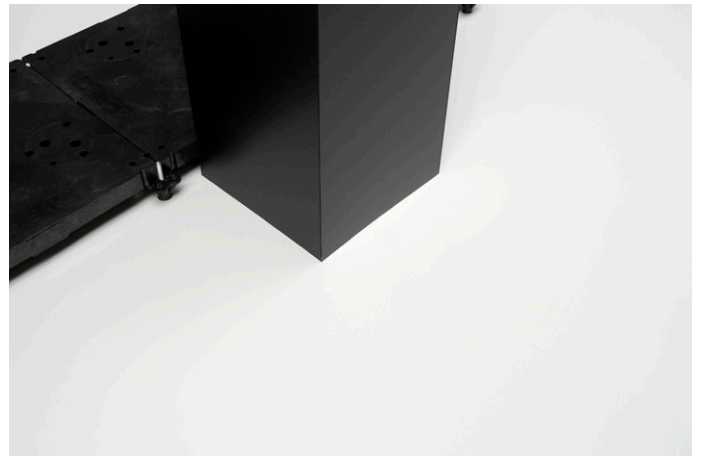
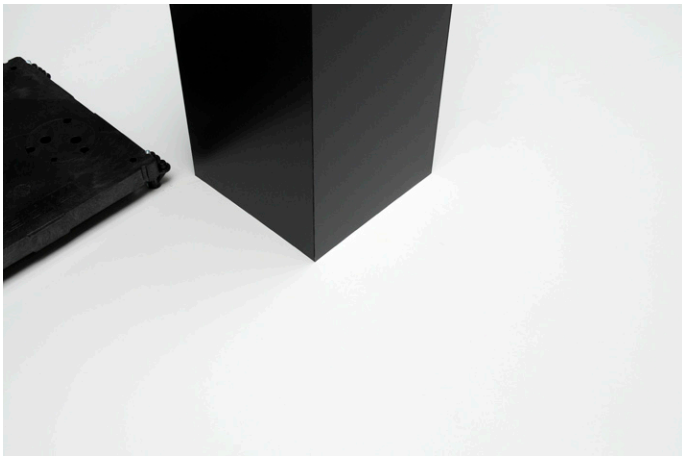

Enhancing dynamic load

car shows:

Primo PX flooring system is often used for car shows, using a finishing of 18mm chipboard.

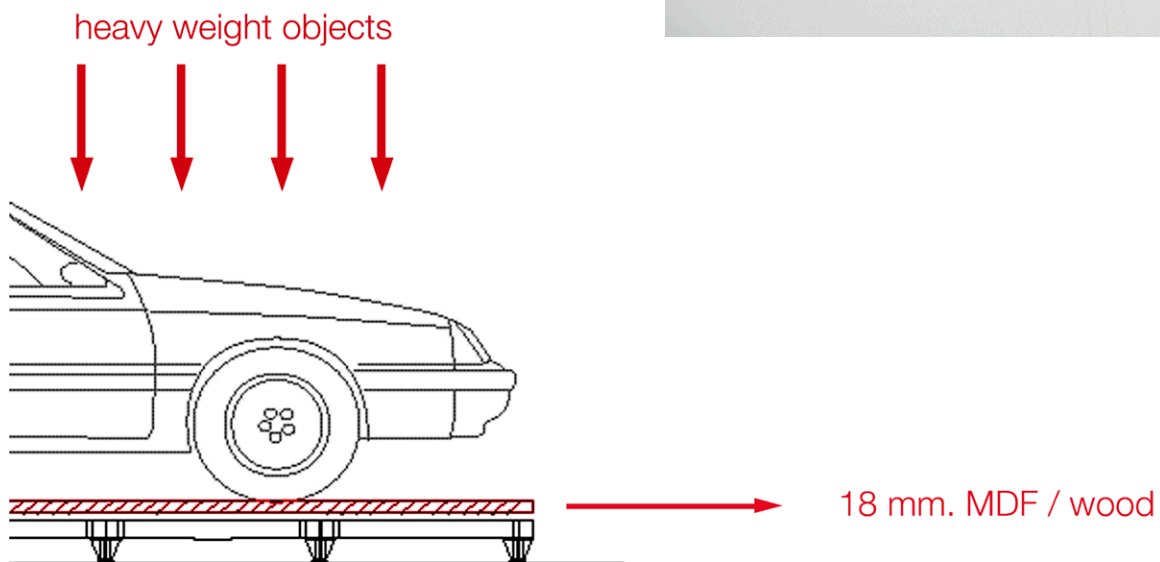
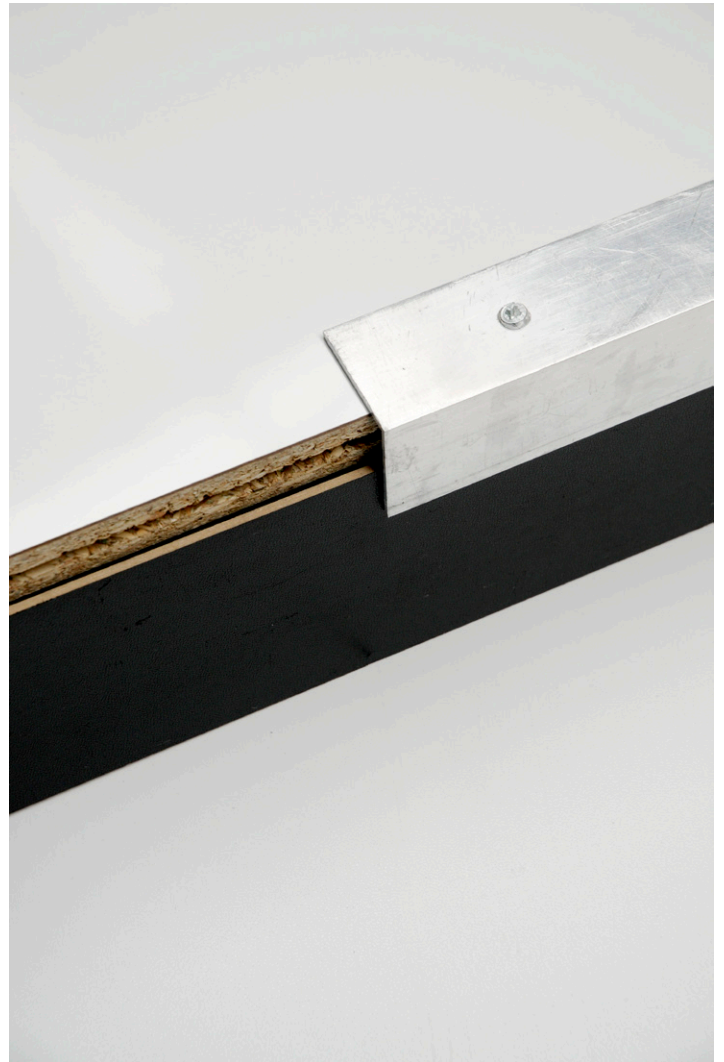

Examples of stands using PRIMO PX flooring system

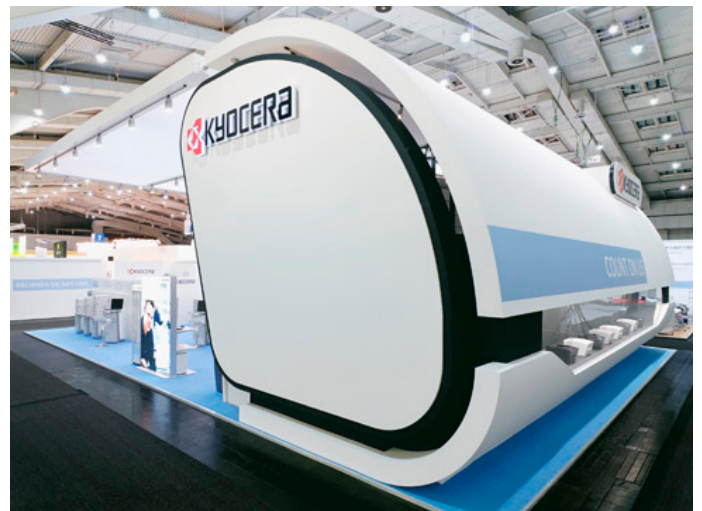

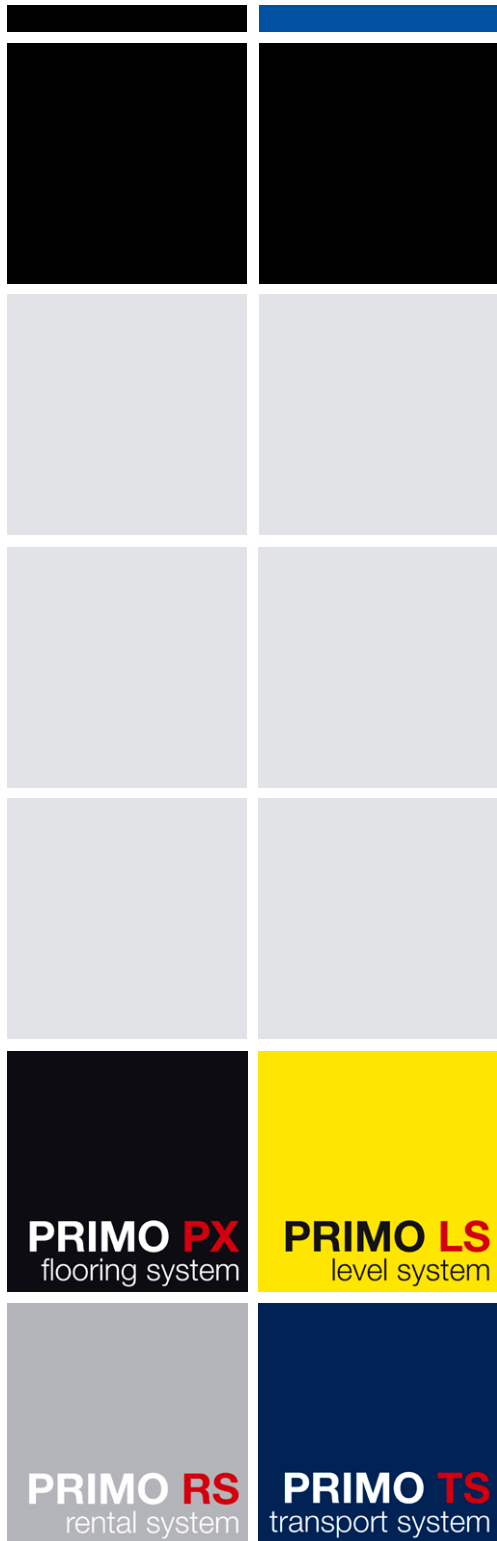

PRIMO PX
flooring system

PRIMO LS
level system

PRIMO RS
rental system

PRIMO TS
transport system

SYCON